

## Global Network

### Houston Engineering and Sales Centre

11757 Katy Freeway, Suite 1100, Houston,  
Texas 77079, USA  
Tel +1.281.599.3377 (201)  
Fax +1.281.599.7734

### Moscow Office

206, 40-4, Bolshaya Ordynka Str. BC Legion-I,  
Moscow 119017, Russia  
Tel +7-499-750-1733

### Milan Office

Viale Brianza, 181, 20092, Cinisello Balsamo,  
Milan, Italy  
Tel +39.02.38608.248

### Abu Dhabi Office

P.O.Box 2621, 5th Floor Guardian Towers,  
Danet Abu Dhabi, Abu Dhabi, U.A.E  
Tel : +971-4-447-8610  
FAX : +971-4-447-8666

### Shanghai Office

200233 20/F, New Caohejing International  
Business Center A, No391, Guiping Road,  
Shanghai, China  
Tel : +86-21-5427-1155  
Fax : +86-21-5423-5122

### Tianjin Office

300385 No.11 Weiliu Road,  
Micro-Electronic Industrial Park,  
Economic- Technological Development Area,  
Tianjin, China  
Tel +86.022.23887788  
Fax +86.022.23887788.8261

### Chengdu Office

610066, 1307, Sunshine Xinye Building 1st, no83,  
Yihuandonglu, Wuduan, Jinjiang District,  
Chengdu, Sichuan  
Tel +86.10.5900.6082  
Fax +86.10.5900.6084

### Headquarters

Hanwha Power Systems R&D Center, 6,  
Pangyo-ro 319beon-gil, Bundang-gu,  
Seongnam-si, Gyeonggi-do, 13488, Korea  
Tel +82.70.7147.4258  
Fax +82.31.8018.3729

### Changwon Plant

1204, Changwon-daero, Seongsan-gu,  
Changwon-si, Gyeongsangnam-do,  
51542, Korea  
Tel +82.55.260.2663, 2492  
Fax +82.55.260.2610

Website : [hanwhapowersystems.com](http://hanwhapowersystems.com)

E-mail : [turbosales@hanwha.com](mailto:turbosales@hanwha.com)



Present State of Hanwha Power Systems  
Turbo Compressor Authentication

- ISO14001 Authentication
- Korea New Technology Authentication
- IR52 Jang Young Sil Award
- ISO9001 Authentication
- CE Authentication
- ASME-compliant
- ISO 8573-1 Class zero Authentication

The information in this publication is  
subject to change without a notice for  
improvement.

# OIL-FREE CENTRIFUGAL AIR COMPRESSOR SM / SM100 SERIES

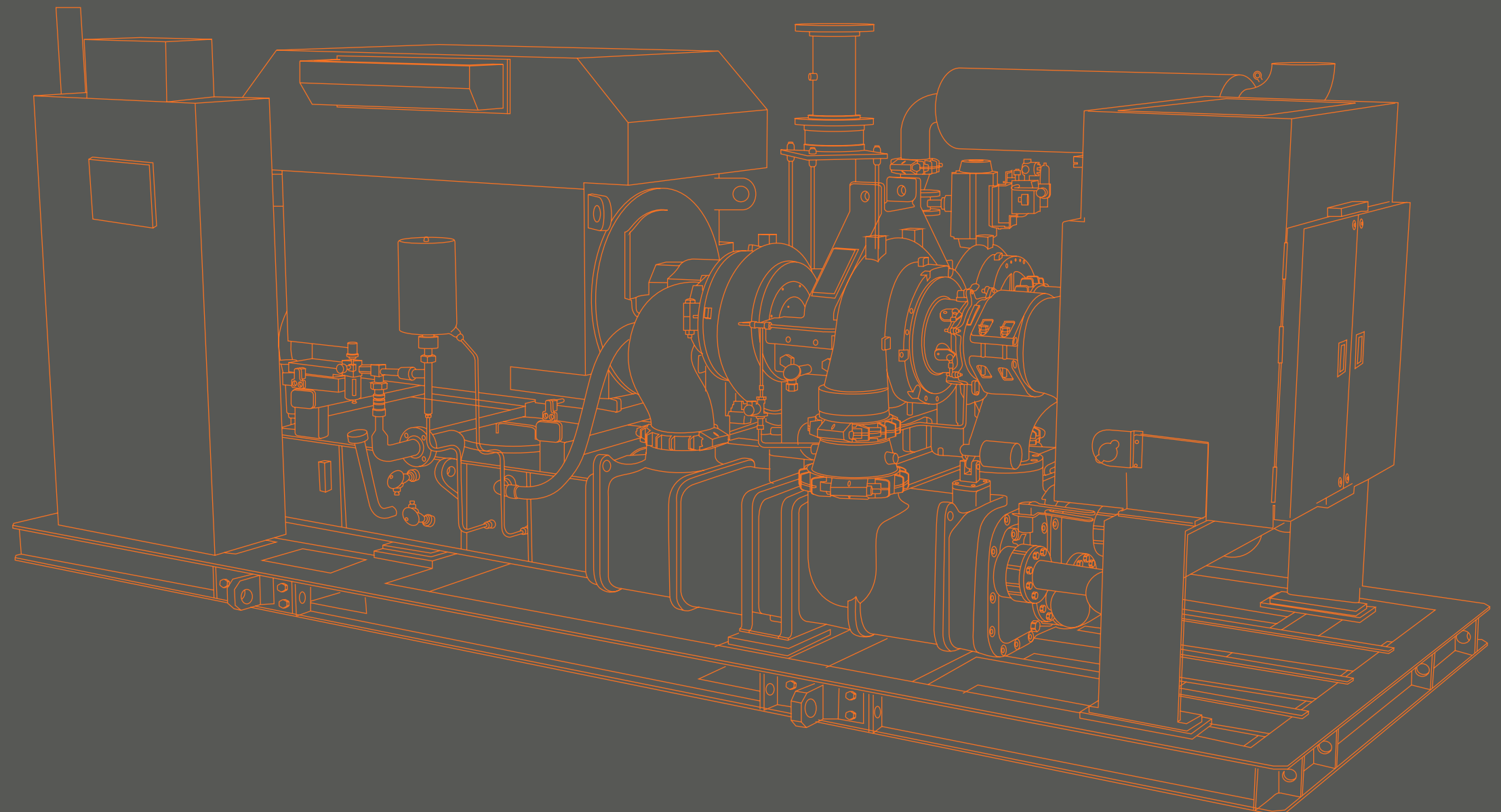

## History

Based on over 35 years of accumulated experience in precision machine industry from Gas Turbine to Compressor Business, Hanwha Power Systems has been chosen by more than w1,000 customers worldwide.

- **1977** Company Established (Samsung Techwin) in Samsung Group
- **1979** Overhaul and Repair of Aircraft Gas Turbine Engines
- **1996** Industrial Gas Turbine Developed
- **1997** First model of Turbo Compressor Introduced
- **2011** Penetrated into Gas Compressor Market
- **2013** SA3100, the World's Largest Capacity of Air Cooled Compressor Introduced ISO8573-1 (Class 0) Certified
- **2014** Contract to Supply the World 1st Integrally Geared Centrifugal Compressor for Offshore VRU Application
- **2015** New Beginning in Hanwha group as "Hanwha Techwin"  
Penetrated into the Offshore Market with Turbo Air & Gas Compressors  
Launched Long-term Aftermarket Service Program  
Expanding Portfolio by Cooperation with Screw Compressor Manufacturers
- **2016** Saudi Aramco Approved Vendor registered (API617 Process Compressor & Blower)  
Reciprocating compressor packager agreement with GE Oil&Gas
- **2017** MOU signed with KEPCO to jointly develop Oxy-Fuel Gas Turbine technology  
New beginning as "Hanwha Power Systems"

Hanwha Power Systems is one of the fastest growing solution providers in its industry since 1997. During the last two decades Hanwha Power Systems delivered over 4,000 units of turbo compressors worldwide.

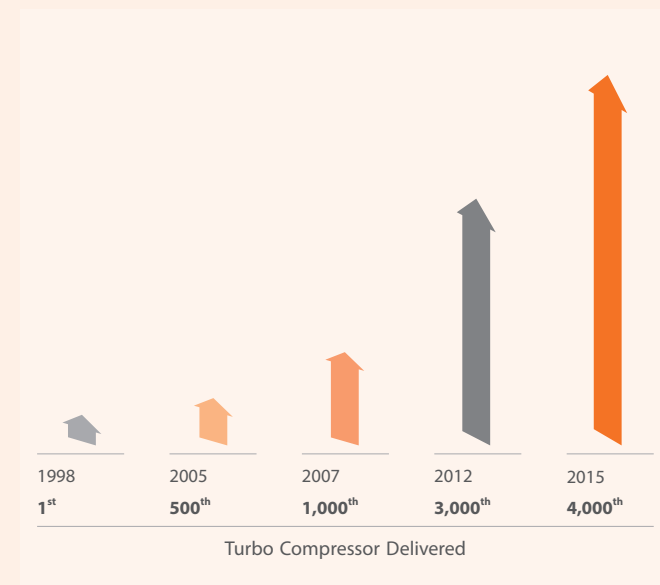

## Industries & Applications

### Upstream & Offshore

- Flash Gas, LP, MP
- Vapor Recovery / Instrument Air

### Refinery

- Make-up, Recycle, Booster (H2, Wet)
- Sulfur Recovery / Process Air / Instrument Air

### LNG

- Boil off gas (Terminal, LNG Plant)
- High Pressure (Terminal)
- Low / High duty (LNGC, LNG FPSO)

### Power Generation

- Fuel Gas Booster / N2 booster (IGCC)
- Syngas / Instrument Air

### Air Separation

- Main Air / Booster Air or N2
- Cryogenic Expansion

### Fertilizer / Gas Processing

- Process Air / Process Gas (NG, NH3, CO2)
- N2 Booster / Instrument Air / NGL

### Petro-chemical

- High Pressure (Terminal)
- Refrigeration (Propane, Propylene)
- PTA / Boil off gas / Process Air / Instrument Air

### Environment & Energy Saving

- Aeration for wastewater treatment
- Pneumatic conveying materials
- Mechanical vapor recompression

## Way to ease your mind

Excellent solution and thorough service will guarantee customer's peace of mind

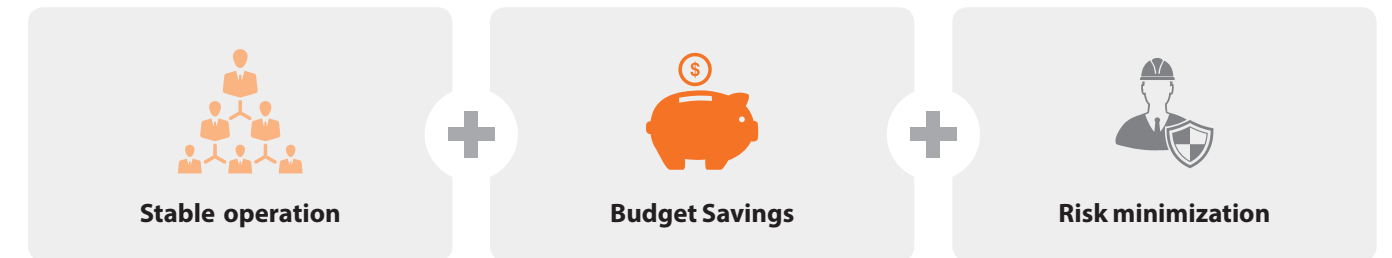

### Stable Operation

- Complying with global industry standards as ISO9001, API672 and customer specific requirements
- 100% Oil-Free compressed air without any contamination: ISO 8573-1 Class 0 certification  
 \* ISO 8573-1 specifies purity classes of compressed air with respect to particles, water and oil independent of the location in the compressed air system at which the air is specified or measured
- Using three-dimensional design system to eliminate potential design flaws in the design phase
- Thorough quality control system to reduce any risk exposure
- The fastest growing in the industry since 1997
- Certified by major players in various industries in the Middle East, Europe, Americas, etc.

### Budget Savings

- High efficiency oriented components and low maintenance design will provide customers with lower life-cycle cost
  - Flexible IGV adjusting the flow rate in accordance with the fluctuation of air consumption to reduce energy consumption up to 7%
  - Wear resistance materials as stainless steel for minimizing abrasion and corrosion
  - Precise 5-Axis machined impeller and long life guaranteed oil and gas seals
  - Simple and no wearing structure leads minimized maintenance effort and cost
- Energy saving analysis to diagnose current status and find the root cause of energy waste can minimize the unnecessary cost and keep customers' profit high

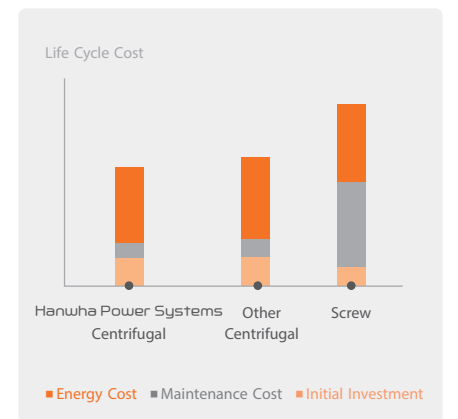

### Risk Minimization

- Preventive maintenance program provides a guideline or an actual check service for keeping customer's equipment healthy
- Remote Monitoring System does daily check of customer's equipment, and provides prompt alarm / notification service once any problem happens
- RUSH112 service and wide range of service network minimizes downtime when emergency situation occurs

## Optimized design to maximize customer benefit

Low maintenance and highly efficient design play a key role to maximize customer profit



### Energy Saving Inlet Guide Vane

- Precise control of air flow by efficient inlet air control
- Reduction of power consumption through partial load control
- Low pressure loss with airfoil profiled vanes



### Durable Coolers

- Water-in-tube inter & aftercooler bundles allow simple maintenance and easy cleaning
- Corrosion / erosion resistant material applied for protecting damage of other components
- Minimizing pressure drop by optimized airflow



### Simple & Neat Package

- Complete full package for plug & run provides easy and low-cost installation
- Full enclosure is applicable for clean appearance and quiet operation which creates a comfortable work environment (Low noise with sound enclosure)
- Minimizing maintenance cost by simple structure



### Leak-Free Lubrication System

- Minimum air leakage reduces losses and increases overall efficiency
- Leakproof gearbox prevents impurities from entering the process
- Complete lubrication system package (Including Oil reservoir, Auxiliary oil pump, Oil heater, Oil demister)



### Maintenance Friendly Gearbox

- Easy maintenance by horizontally split structure
- Minimum cost for inspection and maintenance



### Highly Efficient Main Drive Motor

- Highly efficient package saves energy
- Custom motors are available reflecting client requirements (option)

## Concentrating on efficiency with reliability

Core Unit is the heart of SM Series to achieve high efficiency and reliability by strictly selected optimized components and simple design

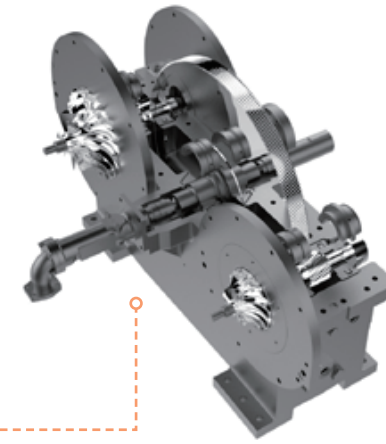

### State-of-the-art 5-Axis Machined Impeller

- Precisely balanced and designed for stability and high efficiency
- Wide operational flexibility with turndown ratio of 30-40%
- 115% over-speed spin test to guarantee reliability
- SUS impellers for extended life cycle with low vibration and low noise



### Long Life Thrust Bearing

- Tilting pad journal bearings applied on pinion gears offer reliable operation and almost permanent life without replacement
- Low friction loss sleeve journal and taper landed thrust bearings are applied on bull gear



### Precise Bull Gear and Pinions

- High precision gear system provides long-life time, low vibration and low noise
- Taper land bearings effectively support axial loads delivered from pinion gears that improve stability of rotation and efficiency
- Easy inspection of gear system without stage disassembly



### Leak-Free Oil & Gas Seals

- Supplies 100% oil-free air in accordance with ISO8573-1 class zero for minimizing loss from downtime
- 4 stages of sealing which satisfies API specification
- Split structure for easy check and maintenance

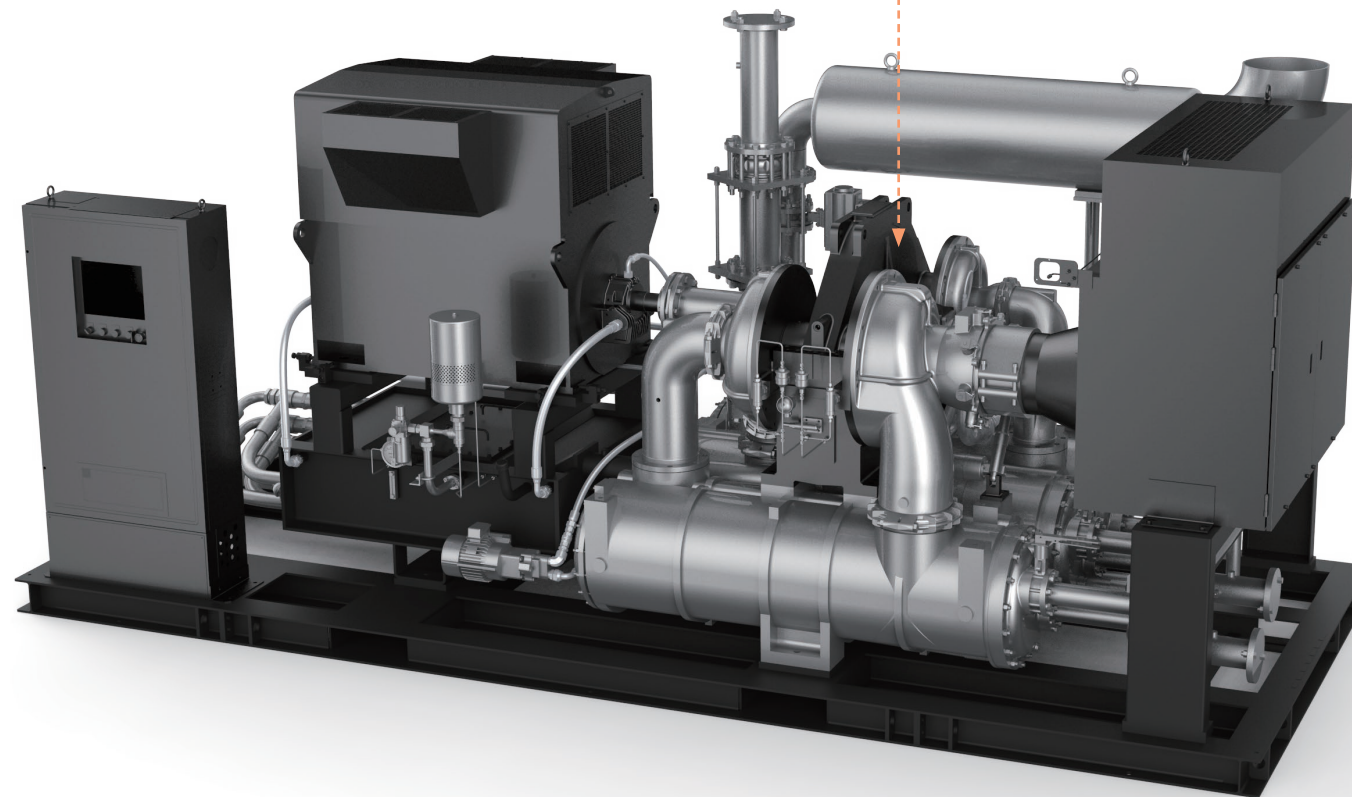

Model		SM3000	SM4000	SM5000	SM6000	
Flow Rate	m <sup>3</sup> /hr	3,300 - 5,300	5,300 - 8,400	8,400 - 15,000	15,000 - 21,000	
	CFM	1,950 - 3,100	3,100 - 4,950	4,950 - 8,850	8,850 - 12,400	
Power	kW	210 - 680	310 - 1,010	490 - 1,540	780 - 2,350	
	HP	282 - 913	410 - 1,350	660 - 1,800	1,050 - 3,150	
Discharge Pressure	bar A	3.5 - 18				
	Psi A	50 - 265				
Dimension (LxWxH)	mm	P	4,750 x 2,100 x 2,500	5,100 x 2,250 x 2,500	5,450 x 2,250 x 2,500	6,200 x 2,300 x 2,550
		S	3,150 x 1,980 x 2,100	3,780 x 2,080 x 2,130	3,960 x 2,100 x 2,350	4,480 x 2,220 x 2,520
	inch	P	187 x 83 x 98	201 x 89 x 98	215 x 89 x 98	244 x 91 x 100
		S	124 x 78 x 83	149 x 82 x 84	156 x 83 x 93	176 x 87 x 99
Weight	kg	P	8,700	10,250	12,950	17,550
		S	7,050	8,400	10,900	15,250

P Package type S Standard type

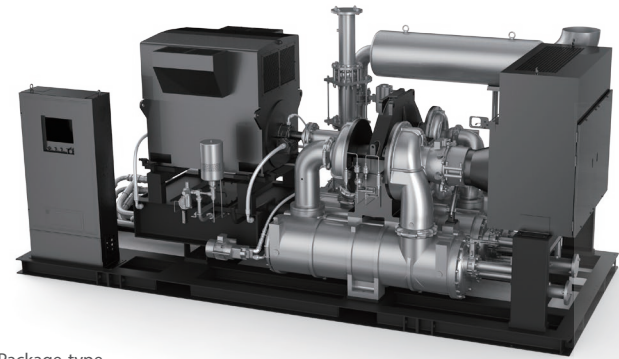

Package type

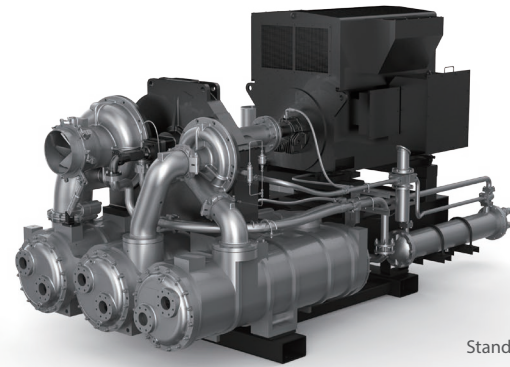

Standard type

## Scope of Supply

- |                                     |                                     |   |
|-------------------------------------|-------------------------------------|---|
| P                                   | S                                   | <input checked="" type="checkbox"/> <input checked="" type="checkbox"/> Air intake filter               |
| <input checked="" type="checkbox"/> | <input checked="" type="checkbox"/> | <input checked="" type="checkbox"/> <input checked="" type="checkbox"/> Inlet guide vanes               |
| <input checked="" type="checkbox"/> | <input checked="" type="checkbox"/> | <input checked="" type="checkbox"/> <input checked="" type="checkbox"/> Blow off valve                  |
| <input checked="" type="checkbox"/> | <input checked="" type="checkbox"/> | <input checked="" type="checkbox"/> <input checked="" type="checkbox"/> Silencer                        |
| <input checked="" type="checkbox"/> | <input checked="" type="checkbox"/> | <input checked="" type="checkbox"/> <input checked="" type="checkbox"/> Check valve and expansion joint |
| <input checked="" type="checkbox"/> | <input checked="" type="checkbox"/> | <input checked="" type="checkbox"/> <input checked="" type="checkbox"/> Complete lubrication system     |
| <input checked="" type="checkbox"/> | <input checked="" type="checkbox"/> | <input checked="" type="checkbox"/> <input checked="" type="checkbox"/> Aftercooler                     |
| <input checked="" type="checkbox"/> | <input checked="" type="checkbox"/> | <input checked="" type="checkbox"/> <input checked="" type="checkbox"/> Drain traps on all coolers      |

- |                                     |                                     |  |
|-------------------------------------|-------------------------------------|--|
| P                                   | S                                   | <input checked="" type="checkbox"/> <input checked="" type="checkbox"/> Main motor             |
| <input checked="" type="checkbox"/> | <input checked="" type="checkbox"/> | <input checked="" type="checkbox"/> <input checked="" type="checkbox"/> PLC control system     |
| <input checked="" type="checkbox"/> | <input checked="" type="checkbox"/> | <input checked="" type="checkbox"/> <input checked="" type="checkbox"/> Base frame             |
| <input checked="" type="checkbox"/> | <input checked="" type="checkbox"/> | <input checked="" type="checkbox"/> <input checked="" type="checkbox"/> Cooling water manifold |
| <input checked="" type="checkbox"/> | <input checked="" type="checkbox"/> | <input checked="" type="checkbox"/> <input checked="" type="checkbox"/> Sound enclosure        |
| <input checked="" type="checkbox"/> | <input checked="" type="checkbox"/> | <input checked="" type="checkbox"/> <input checked="" type="checkbox"/> Dual oil filter        |
| <input checked="" type="checkbox"/> | <input checked="" type="checkbox"/> | <input checked="" type="checkbox"/> <input checked="" type="checkbox"/> Block valve            |
| <input checked="" type="checkbox"/> | <input checked="" type="checkbox"/> | <input checked="" type="checkbox"/> <input checked="" type="checkbox"/> Companion flange       |

- |                                     |                                     |  |
|-------------------------------------|-------------------------------------|--|
| P                                   | S                                   | <input checked="" type="checkbox"/> <input checked="" type="checkbox"/> Hot air piping                     |
| <input checked="" type="checkbox"/> | <input checked="" type="checkbox"/> | <input checked="" type="checkbox"/> <input checked="" type="checkbox"/> Auto trap                          |
| <input checked="" type="checkbox"/> | <input checked="" type="checkbox"/> | <input checked="" type="checkbox"/> <input checked="" type="checkbox"/> MODBUS / PROFIBUS Interface        |
| <input checked="" type="checkbox"/> | <input checked="" type="checkbox"/> | <input checked="" type="checkbox"/> <input checked="" type="checkbox"/> Motor winding / bearing protection |

P Package type S Standard type  
 Standard  Options  Not applicable

## Customer Oriented Monitoring System

Provides convenient operation and accurate control

### High-resolution Color LCD Touch Screen Panel

- Touch screen size : 7.0" Wide or 10.2" Wide
- Resolution / Color : WVGA 800 x 480 / 65k Color

### Reliable and Stable Control System

- Conforms to EMC international standard during in operation: CE, RE, CS, RS, ESD, Surge, Burst (CISPR 11 Class A, IEC 61000-4)

### User Friendly Interface with Improved Operability and Legibility

- Conversion to ICON / animation of main information as operation / stop, valve status etc.
- Quickly and easily switchable screen by navigation bar

### Complete Control Package

### Automatic Control

- Optimization of surge control margin : High turndown ratio through minimizing surge margin
- Precise pressure control in overall operation range
- Local / Remote control function
- Self check and automatic resolution logic against errors

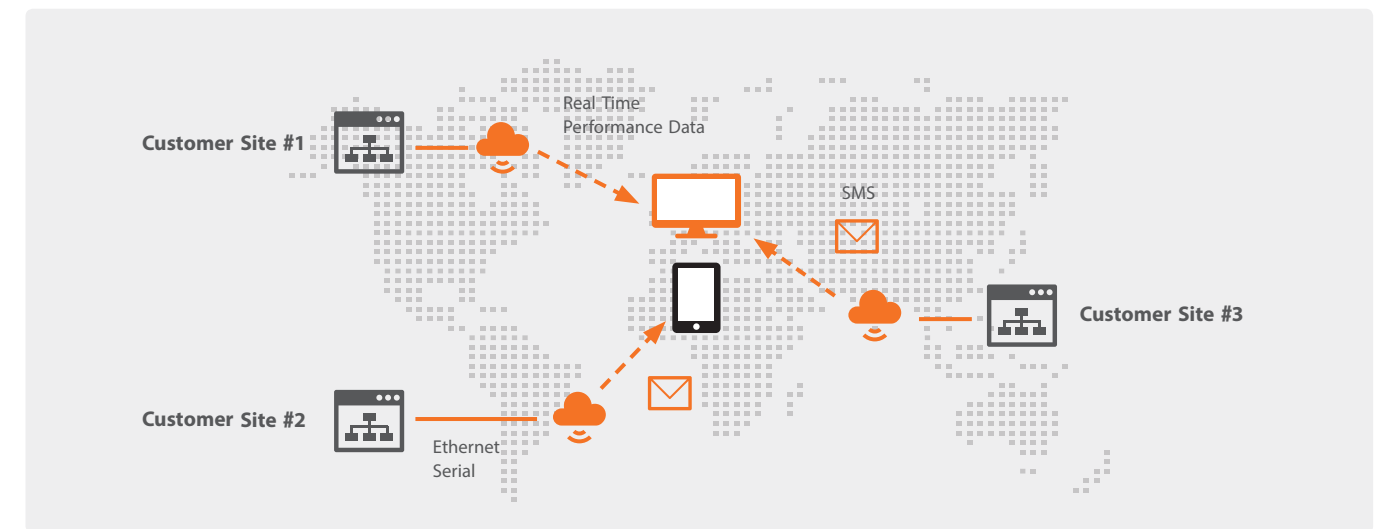
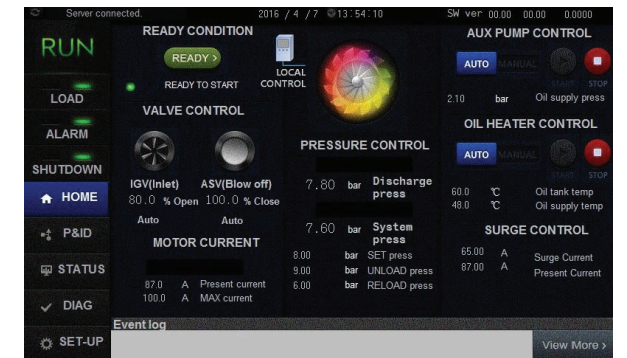

- Real-time monitoring by PC and smartphone
- Warning and trouble shooting message transferred once alarm or shutdown occurs

- Compressor remote management and energy saving solution

Hanwha Power Systems provides total care service, called Smart Care, ranging from current equipment diagnosis to urgent repair service to get rid of customer risks. This prevents unnecessary energy loss and minimizes downtime that may occur.

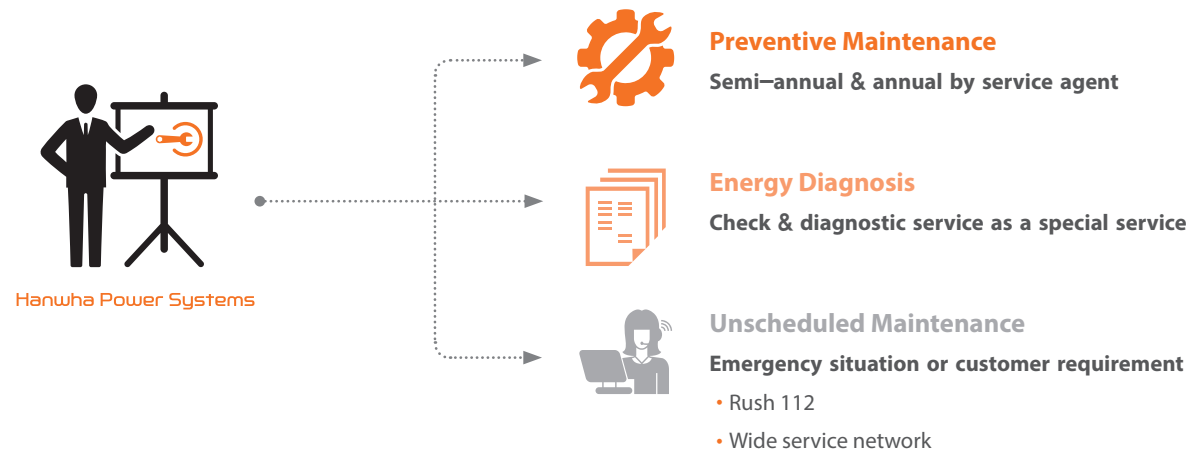

## Energy Diagnosis

Operators expect equipment to run in an optimized mode. In many cases, however, it is hard to notice small changes leading to inefficiencies in its operation. Hanwha Power Systems provides diagnosis service inspecting if current equipment is being operated properly and efficiently. Through this Service, customers can learn which part causes energy loss and how to improve the efficiency. Ultimately customers minimize waste and maximize profitability.

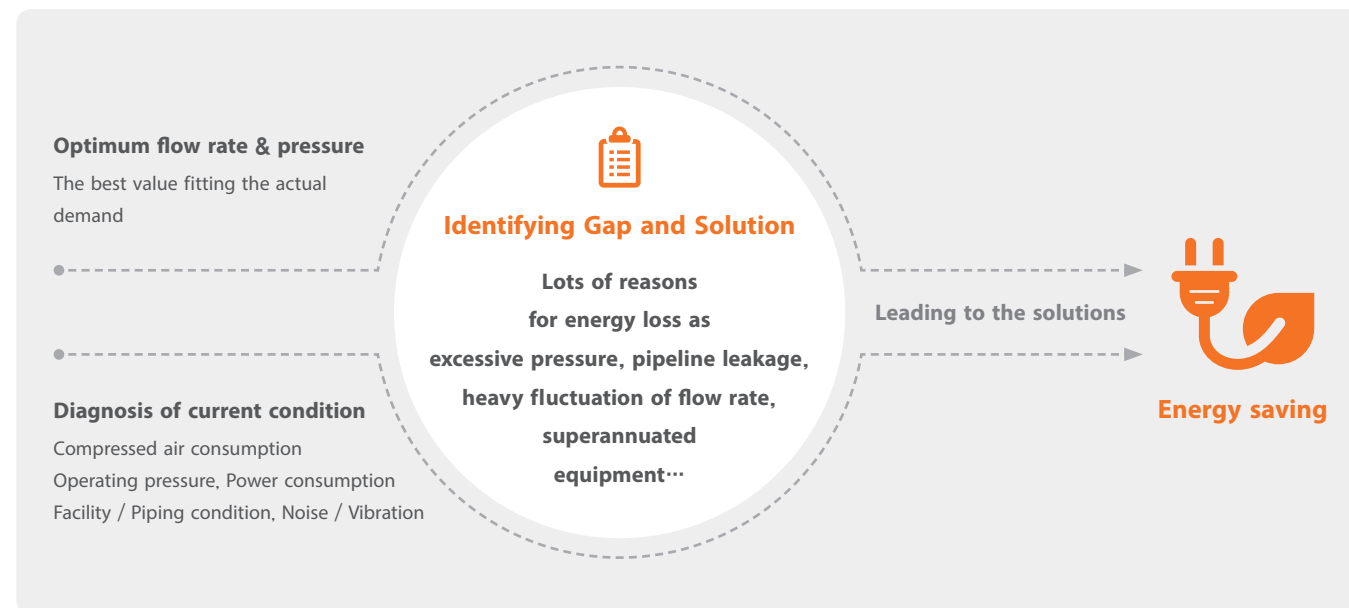

## Preventive Maintenance program

To prevent malfunction during operation, Hanwha Power Systems provides 4 programs by operating time and specific programs are customized per each customer's requirements. This program will enable customer equipment running stably without any problem so that customers can minimize downtime, low life cycle cost through saving additional trouble shooting cost.

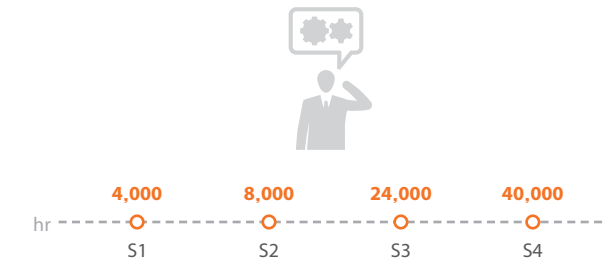

## Rush 112 Worldwide

Hanwha Power Systems is willing to provide immediate service to customers worldwide based on RUSH 112 philosophy.

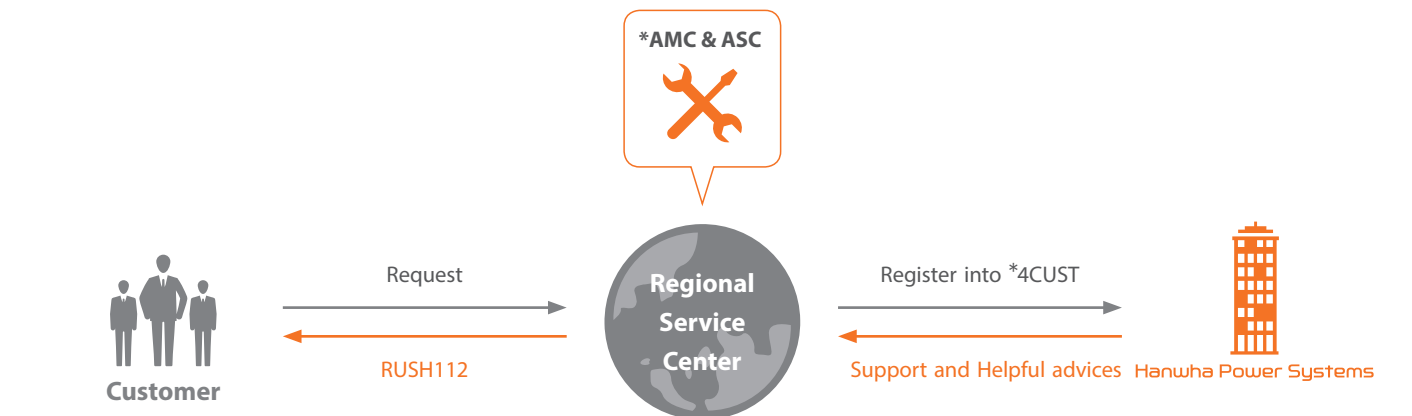
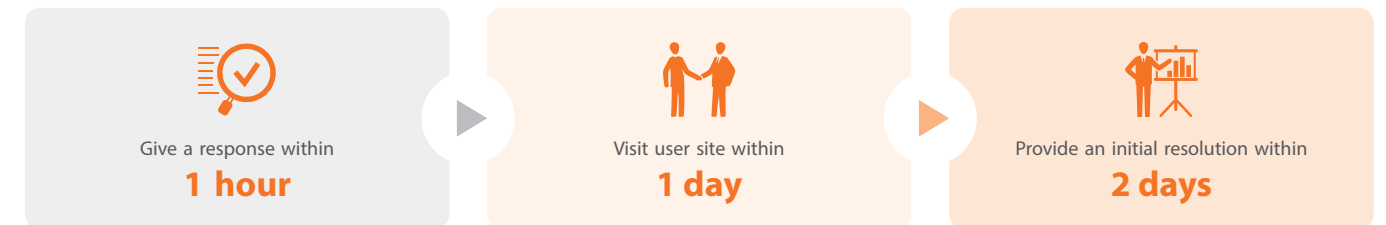

\* 4CUST: Customer-centric 4C oriented system (4C: Consumer, Cost, Convenience, Communication)

\* AMC: Authorized Maintenance Center

\* ASC: Authorized Service Center

# Introduction to Hanwha Group

## Hanwha Businesses

a FORTUNE Global 500 Company

64 years of business experience with 190 global networks

2015 Total assets of \$146billion and total sales of \$53billion

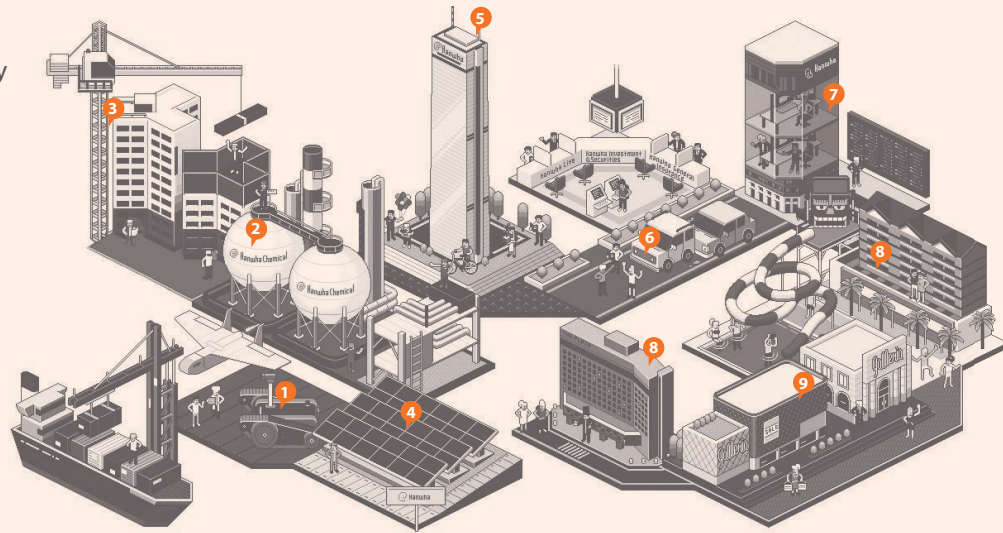

### Manufacturing & Construction

- Hanwha Corporation ①
- Hanwha Techwin ①
- Hanwha Power Systems ①
- Hanwha Land Systems ①
- Hanwha Precision Machinery ①
- Hanwha Thales ①
- Hanwha Chemical ②
- Hanwha General Chemical ②
- Hanwha Total Petrochemical ②

- Hanwha Fine Chemical ②
- Hanwha Engineering & Construction ③
- Hanwha Q CELLS ④
- Hanwha Q CELLS Korea ④
- Hanwha Advanced Materials
- Hanwha Energy
- YEochun NCC
- Hanwha City Development

### Finance

- Hanwha Life ⑤
- Hanwha General Insurance ⑥
- Hanwha Investment & Securities ⑦
- Hanwha Asset Management ⑧
- Hanwha Investment
- Hanwha Savings Bank

### Services & Leisure

- Hanwha Hotels & Resorts ①
- Hanwha Galleria ⑨
- Hanwha Galleria Tmeworld
- Hanwha 63 City ⑤
- Hanwha S&C
- Hanwha Station Development

## Global Network

190 Global Networks (As of June 2015)

- |                 |                   |              |              |
|-----------------|-------------------|--------------|--------------|
| Ponitac         | London            | Bismayah     | Seoul        |
| Chicago         | Weybridge         | Kuwait city  | Tokyo        |
| Bremen          | Aix-en-Provence   | Tehran       | Nagasaki     |
| Franklin        | Stuttgart         | Dubai        | Fukuoka      |
| London(Ontario) | Warsaw            | Baghdad      | Shenzhen     |
| Forest          | Eschborn          | Almaty       | Chongqing    |
| New York        | Ismaning          | Mumbai       | Guangzhou    |
| Cranbury        | Bitterfeld-Wolfen | New Delhi    | Beijing      |
| Bakersfield     | Berlin            | Yangon       | Linyungang   |
| Irvine          | Dietfurt          | Bangkok      | Hangzhou     |
| Shelby          | Diosd             | Samut Prakan | Ningbo       |
| Hawaii          | Budapest          | Ho Chi Minh  | Zhangjiagang |
| Monterrey       | Moscow            | Phnom Penh   | Shanghai     |
| Hartford        | Frydek-Mistek     | Selangor     | Qidong       |
| Teaneck         | Bolzano           | Kuala Lumpur | Dongguan     |
| Ridgefield park | Athens            | Singapore    | Suzhou       |
| Opelika         | Istanbul          | Jakarta      | Tianjin      |
| Monroe          |                   | Manila       | Hong kong    |
| Sao Paulo       |                   | Saipan       | Taipei       |
| Santiago        |                   |              | Sydney       |
|                 |                   |              | Johannesburg |

58 Affiliates all over the world

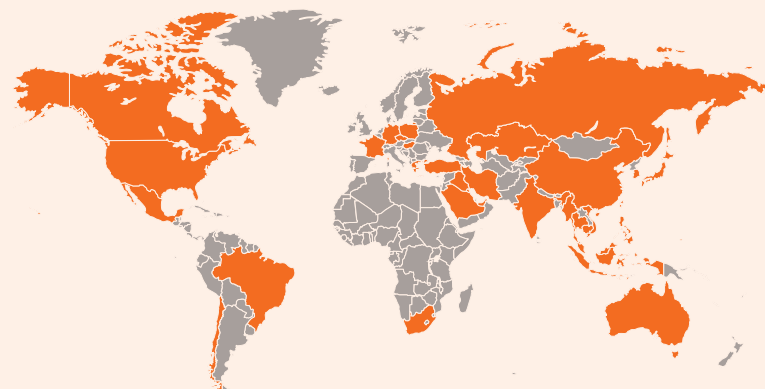

## Wide Service Network

Provides prompt service for customers around the world, Hanwha Power Systems has built a large number of centers globally. Customers can ask for service at anytime through those centers and get solutions in time.



- Office
- AMC (Authorized Maintenance Center) & ASC (Authorized Service Center)

Belarus	India	Malaysia	Thailand
Brazil	Indonesia	Mexico	Turkey
China	Iran	Poland	Ukraine
Czech	Kazakhstan	Russia	USA
Finland	Korea	Taiwan	Vietnam